



COMPARISON OF MPPT ALGORITHMS FOR DC-DC BOOST CONVERTER IN GRID-TIED PHOTOVOLTAIC SYSTEMS

Ahmed. E. A. Hussien¹, Ahmed Emad-Eldeen¹, Praveen C Ramamurthy² , Nabila Shehata³ , Walid S. E. Abdellatif⁴ 

¹Renewable Energy Science and Engineering Department, Faculty of Postgraduate Studies for Advanced Sciences (PSAS), Beni-Suef University, Beni-Suef 62511, Egypt

²Inter Disciplinary Centre for Energy Research (ICER), Indian Institute of Science (IISc), Bangalore - 560012 Karnataka, India.

³Environmental Science and Industrial Development Department, Faculty of Postgraduate Studies for Advanced Sciences (PSAS), Beni-Suef University, Beni-Suef 62511

⁴Electrical Department, Faculty of Technology and Education, Suez University, 43221, Suez, Egypt.

elsayedahmed966@yahoo.com, ahmed.emad@psas.bsu.edu.eg, Nabila.shehata@psas.bsu.edu.eg, and Walid.Abdellatif@ind.suezuni.edu.eg

DOI: 10.15598/aeec.v22i2.5318

Article history: Received Jul 10, 2023; Revised Mar 19, 2024; Accepted May 02, 2024; Published Jun 30, 2024. This is an open access article under the BY-CC license.

Abstract. *In unpredictable weather circumstances, a maximum power point tracking (MPPT) approach is critical for ensuring maximum photovoltaic (PV) output power is extracted. In this paper, we will compare the incremental conductance algorithm (IC), perturb and observe (p&o), and fuzzy logic controller (FLC) as maximum power point tracking (MPPT) techniques. The three algorithms were used on a photovoltaic energy conversion system that was linked to a grid. The suggested methodologies investigate the photovoltaic (PV) system's solar energy conversion performance under various irradiance and temperature circumstances. Lastly, a performance comparison between IC, P O, and FLC has been performed, demonstrating the superiority of the fuzzy controller over the other approaches. FLC converts photovoltaic electricity readily, reducing fluctuations, and it responds quickly to variations in solar irradiation (the shading effect). The simulation results demonstrate that the controller using fuzzy logic performs well, allowing the inverter to convert the electricity provided by the solar panels.*

1. Introduction

It was necessary to rely on additional sustainable sources of energy because of the rising demand for electric energy globally. The sun's energy is one of these. Photovoltaic (PV) panels used to generate electricity from solar energy make up the most prevalent and widely used alternate forms of energy [1]. Due to its benefits, such as being a renewable and environmentally friendly energy source, PV energy has been expanding quickly in recent years [2]. PV panels are exposed to a variety of factors when they are outdoors, including wind, rain, snow, heat, lightning, shading, and others, which slows down their productivity and causes them to degrade over time [3]. As a result, it is necessary to investigate how weather conditions affect the efficiency of photovoltaic systems [4]. Maximum power is extracted from the photovoltaic (PV) panel using the Maximum Power Tracker (MPPT) methods [5, 6]. The methods used to track MPP include incremental conductance (IC) [7–11], (P and O) [11–15], and (FLC) [15–19]. This research provides a system for obtaining MPPT based on various factors using the FLC method. The FLC was operated under various working conditions of temperature and solar radiation, and the results were compared. The most important contribution of this essay is the workable and athletic examination of the suggested approach (FLC). In addition, the P&O method and the IC method are designed and im-

Keywords

FLC; P&O; IC; MPPT; PV; dc/dc converter; MATLAB; SIMULINK.

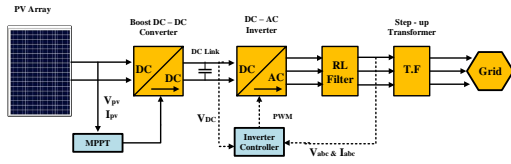

Fig. 1: A graphical diagram of the suggested model.

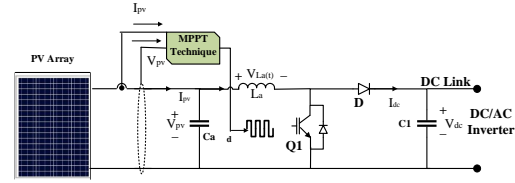

Fig. 4: Displays the DC-DC boost converter diagram.

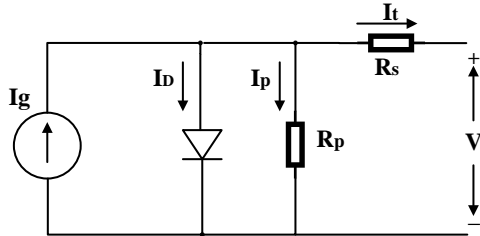

Fig. 2: Solar cell equivalent circuit.

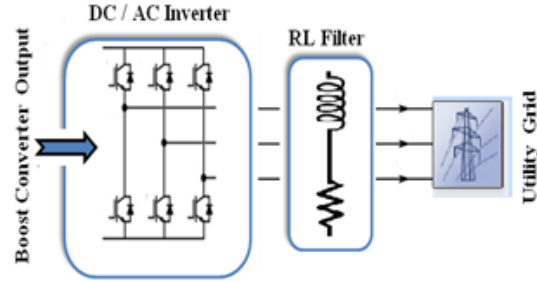

Fig. 5: DC-AC inverter diagram.

plemented, and the results are compared between the three methods. There are five different sections in this paper: Sec. 2. contains the design of the proposed model. Sec. 3. deals with the boost converter (BC) and explains the essentials of the FLC, P&O, and IC methods. Sec. 4. provides the results attained from the simulation. The conclusion is in Sec. 5. .

2. Design of the proposed model

The model suggested is a photovoltaic system linked to a three-phase system. This model consists of six sections, as illustrated in Fig. 1. The first section shows the PV array. A converter is shown in the second section; the third section is a DC/AC inverter; the fourth section is an RL filter; the fifth section is a transformer; and the last is the electric grid. The control portion of MPPT is the last section.

2.1. PV panel modeling

The solar cell is depicted in Fig. 2 as a single diode coupled with resistance in parallel and a string. To get the desired current and voltage, the cells are linked together in series or parallel [20]. (V-I) and (P-V) curves for the suggested model under different effects of solar radiation are depicted in Fig. 3(a) and Fig. 3(b), respectively.

The link between solar cell outputs is illustrated by the following relationship:

$$I = IL - I_0 \left\{ \exp \left(\frac{q(v + RsI)}{NsAKT} \right) - 1 \right\} - \left\{ \frac{v + RsI}{Rsh} \right\}, \tag{1}$$

$$IL = [I_{L,N} + \Delta i \Delta T] \left(\frac{w}{wN} \right), \tag{2}$$

$$I_0 = \frac{isc, n + \Delta v. \Delta T. I}{\exp \left(\frac{voc, n + \Delta v. \Delta T}{NsKT A/q} - 1 \right)}, \tag{3}$$

Whereas I output current of the PV, I_0 diode saturation current, I_L light generated current, Q charge of

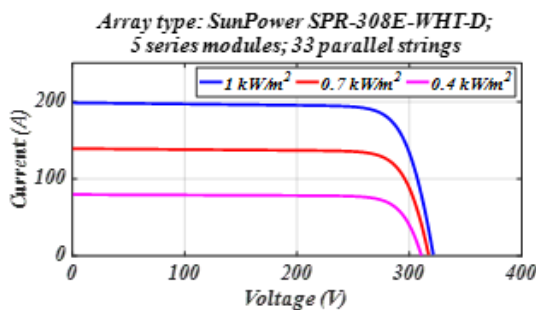

(a)

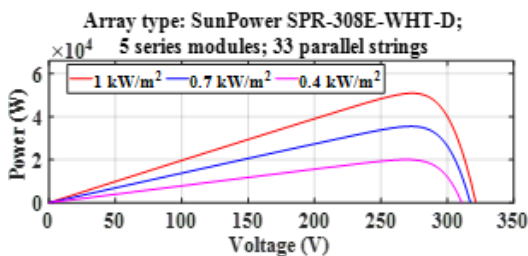

(b)

Fig. 3: (a) the relationship between (V-I) and (b) the relationship between (P-V) for the suggested model under different effects of solar radiation.

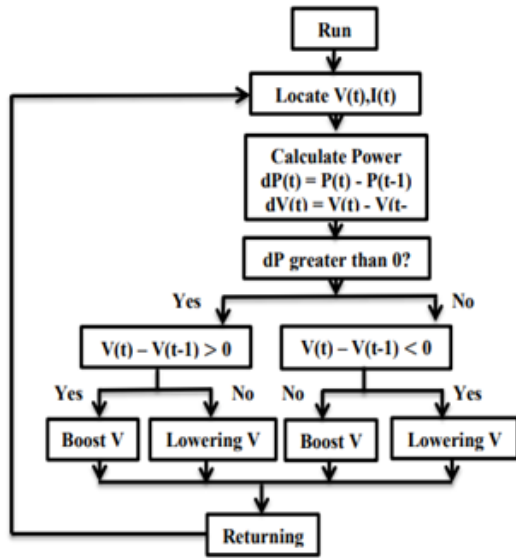

Fig. 6: Describes the P&O method.

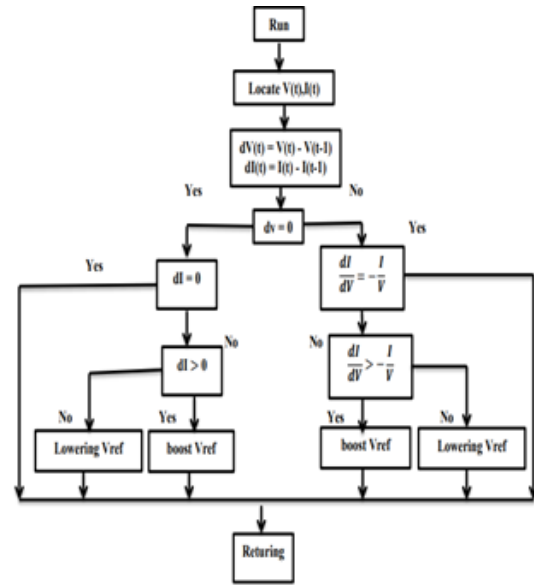

Fig. 7: Describes the IC method.

the electron (1.6×10^{-19})[C], V terminal voltage of the PV, R_s series resistance, N_s is how many cells are in series, K Boltzmann parameter, T cell temperature (K), R_{sh} size of the shunt's cells, A diode ideality agent, ΔI the proportion of short circuit current difference, ΔV the proportion of short circuit current difference, W Irradiance and W_N Nominal Irradiance.

2.2. DC-DC boost converter (BC) Modelling

The boost converter's primary duty is to raise the voltage coming out of the solar cells to the desired level using PWM, and it tracks the maximum power point using a set of algorithms. The boost converter is connected between the solar cells and the load [21]. The components of this converter are the IGBT used as a switch, which is controlled by PWM, the diode, the inductive coil (L), and the output voltage, which is smoothed using the capacitor C2. Fig. 4 displays the DC-DC boost converter diagram.

The following relationship describes how the boost converter works:

$$V = V_s \frac{1}{1 - d}, \tag{4}$$

Whereas: V is the terminal voltage, V_s is the source voltage, and d is duty cycle ($0 < d < 1$).

2.3. DC-AC inverter

A DC/AC inverter is a vital component in a grid-connected PV system, as it performs the essential task

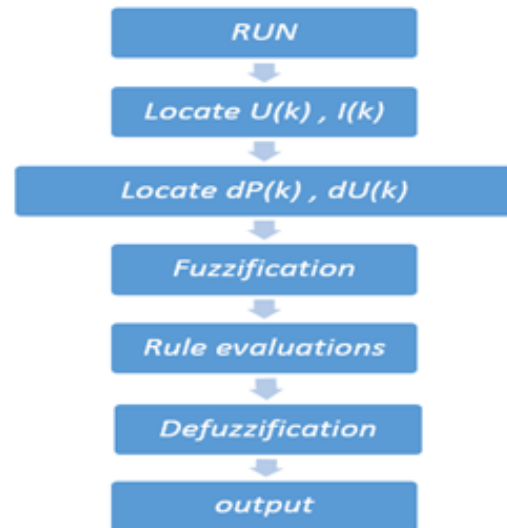

Fig. 8: Describes the FLC method.

of converting the DC electricity generated by PV panels into AC electricity that can be seamlessly integrated with the electrical grid. The DC/AC inverter enables the PV system to supply excess electricity to the grid and reduce energy consumption when generation exceeds local demand. Similarly, when the PV system's generation is not enough, the inverter allows drawing power from the grid to meet the demand. Fig. 5 displays the DC-AC inverter diagram.

2.4. RL filter

An RL filter is a crucial component in photovoltaic (PV) systems, aimed at minimizing the presence of unwanted harmonics and disturbances. This filter config-

uration comprises a resistor (R) and an inductor (L) interconnected in a series arrangement, as shown in Fig. 5. The inductor functions to stabilize variations in voltage and current, whereas the resistor aids in dispersing surplus energy by converting it into heat. By employing this type of filtration mechanism, PV systems can experience enhanced operational effectiveness and energy utilization.

2.5. Transformer

The 3-phase transformer in a grid-tied photovoltaic system is essential for efficient power conversion, phase matching, and grid connection, enabling the seamless integration of renewable solar energy into the existing power grid infrastructure.

3. Maximum power point tracking (MPPT) Techniques

3.1. Perturb and Observe (P&O) MPPT Technique.

For MPPT control, the P&O algorithm is simpler and less expensive. In the P&O algorithm, the PV output power's present value is determined and compared to its preceding value to get the power differential, or dp (p_ Present-p_(Past)). If dp is greater than zero, the operation remains the same while being perturbed; otherwise, it travels in the other direction [21,22]. Fig. 6 describes the P&O algorithm.

3.2. Incremental Conductance Algorithm (IC).

The IC technique can be used to overcome the P&O technique's failure under quickly variable ecological conditions. The foundation of the IC algorithm is the slope of an SPV array's P-V curve [23]. Taking into account that power is defined as the product of the voltage and the current, up until we achieve the MPP on the voltage/current curve, the power is compared to the voltage as indicated in the equations [24]. Fig. 7 describes the IC algorithm.

$$\left\{ \begin{array}{l} \text{if } : \frac{\delta I}{\delta U} = -\frac{I}{U}, @MPP \\ \text{if } : \frac{\delta I}{\delta U} > -\frac{I}{U}, @LefttheMPP \\ \text{if } : \frac{\delta I}{\delta U} < -\frac{I}{U}, @RighttheMPP \end{array} \right\}. \quad (5)$$

3.3. Fuzzy Logic Controller (FLC) Algorithm

In intricate procedures, find that FLC produces better outcomes when compared to the use of traditional methods. It is employed in many challenging applications since it is adaptable and has a quick response time. Fig. 8 helps to explain how the FLC technique works. The FLC Technique is built around four basic structures:

- Fuzzifier
- Rule evaluations.
- Inference engine.
- Defuzzifier

1) Fuzzifier

Is the first stage. The input elements in this situation are converted into linguistic factors, which depend on numerous characterized enrollment capacities.

2) Rule evaluations.

According to rules based on the "if-then" principle that directs the framework's ideal operation, these linguistic aspects are controlled in the second stage, as shown by rules based on the "if-then" principle that directs the framework's ideal operation.

Tab. 1: Fuzzy rules.

e	C _e						
	pl	pm	ps	z	lp	mp	bp
pl	bp	bp	bp	bp	mp	z	z
pm	bp	bp	lp	mp	lp	z	z
ps	bp	mp	lp	lp	mp	z	z
z	bp	mp	lp	z	ps	pm	pl
lp	z	z	ps	ps	ps	pm	pl
mp	z	z	ps	pl	pm	pl	pl
bp	pl	z	mp	pl	pl	pl	pl

3) Defuzzification

It is the final step in the fuzzy inference process because it turns the fuzzy values obtained during the inference stage into numerical values. The cycle of duty, which is utilized to regulate the boost converter's running, is the FLC's output. In the suggested controller seen in Figure 8, fuzzy controller inputs are divided into two parts. The first part is the error signal E, and the second part is a disparity in the error signal CE. To maintain the MPP, the error signal (E) should be

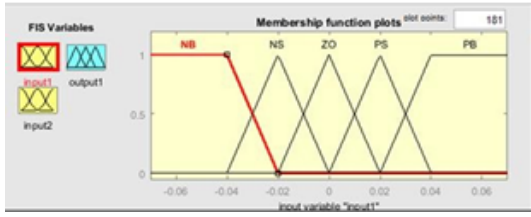

Fig. 9: Membership functions for the input variable E.

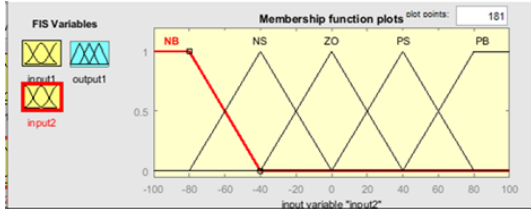

Fig. 10: Membership functions for the input variable CE.

zero [9, 21].

$$e(i) = [Po(i) - Po(1 - i)]/[Vo(i) - Vo(1 - i)], \quad (6)$$

$$ce(i) = e(i) - e(i). \quad (7)$$

The BC keeps track of the mmp based on the duty cycle come from the FLC (fuzzy factor). as displayed in Table 1, There are seven language labels that describe the I/O variables. Such as positive small p_s , low passive L_p , positive medium p_m , moderate passive m_p , positive large p_l , big passive (b_p) and zero (z). Table 1 shows the fuzzy applicable rules foundation.

Fig. 9 displays the input variable, referred to as the error (E). Fig. 10 illustrates another input variable, known as the change error (CE). Lastly, Fig. 11 represents the output variable, which is the duty ratio (D). Fig. 12 presents the rule viewer in MATLAB and the overview of control.

4. Simulation Results

MATLAB processing condition is utilized to show the proposed method of legitimacy on the PV network associated framework. The framework specifics are indicated in Table 2.

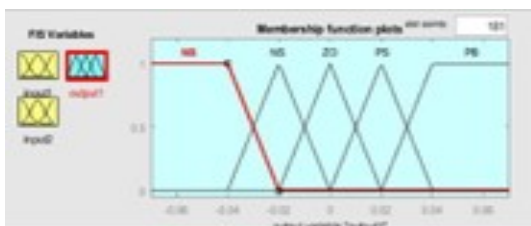

Fig. 11: Membership functions for output variable D.



Fig. 12: Rule viewer in MATLAB windows of fuzzy logic controller.

Tab. 2: PV System parameters.

Parameters	Values
Maximum Power (W)	308 W
Current At Maximum Power Point Imp (A)	5.64 A
Voltage At Maximum Power Point Vmp (V)	54.7 V
Open Circuit Voltage Voc (V)	64.3 V
Short-Circuit Current Isc (A)	6.02A
Parallel Strings	33
Series-Connected Modules Per String	5
light generated current	6.0258A
shunt resistance	403.8158 Ω
series resistance	0.38767 Ω

4.1. The influence of the alteration in temperature on the output.

1) The influence of temperature alteration on PV's output.

The suggested model was created and implemented using MATLAB, as shown in Fig. 13. Fig. 14 presents the varieties of temperature with consistent radiation (STC), as temperature starting from 75 (Deg. C) was step by step declined to 50 (Deg. C) and a short time later reduced temperature until 25 (Deg. C). Fig. 15 displays the suggested system output (V, I, and P) utilizing three approaches. The findings indicate that the suggested system output using P&O and IC is unstable when the temperature changes, but using FLC, the system output is stable, and the MPP can be tracked with accuracy and high speed. Table 3 shows the PV power under different temperatures between three different strategies.

Tab. 3: PV power under different temperature.

Time (sec)	Temperature (Deg. C)	(P kilowatt)		
		IC	P&O	FLC
0 : 3.5	75	40.39	41.78	43.02
3.5 : 7	50	43.38	45.63	47.03
7 : 10	25	47.81	49.36	50.89

It has been noted from the previous results that using FLC to track MPP achieves a quick response and

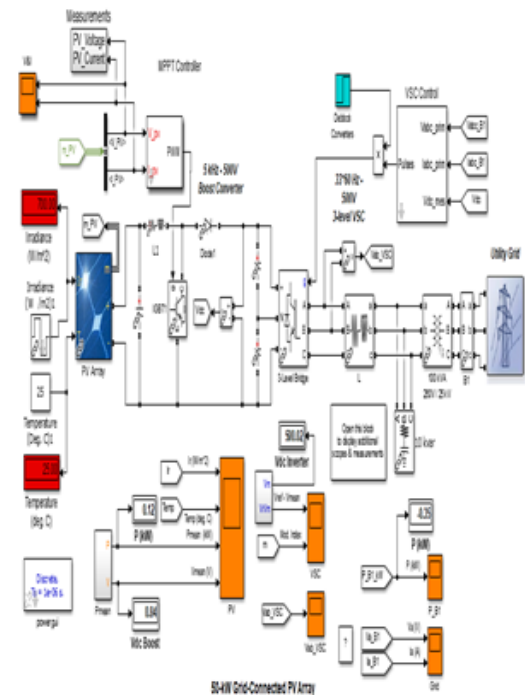

Fig. 13: Illustrates the block diagram of the proposed algorithms.

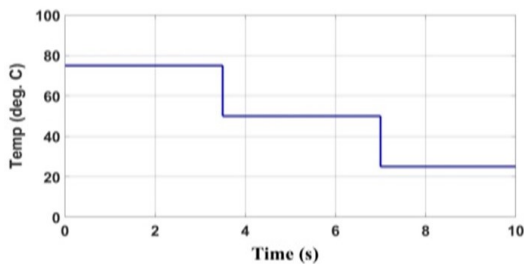

Fig. 14: Temperature curve.

makes the system more stable when the temperature changes.

2) The impact of temperature change on the grid's output

Fig. 16 shows the grid power when applying the MPP algorithms, and Table 4 display the results.

Tab. 4: PV power under different temperature.

Time (sec)	Temperature (Deg. C)	(P kilowatt)		
		IC	P&O	FLC
0 : 3.5	75	39.79	41.11	42.40
3.5 : 7	50	42.74	45.03	46.38
7 : 10	25	47.22	48.73	50.62

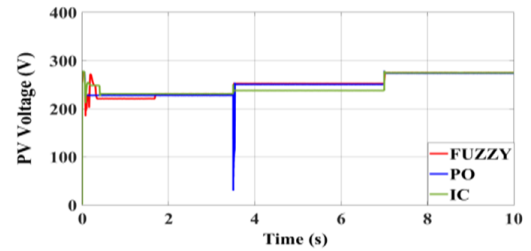

(a)

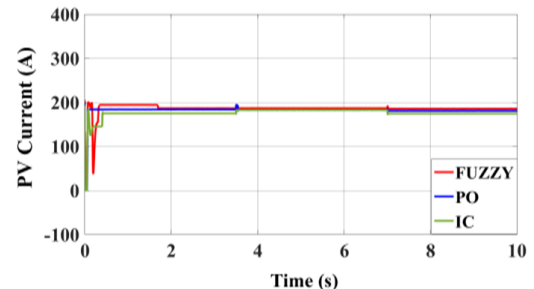

(b)

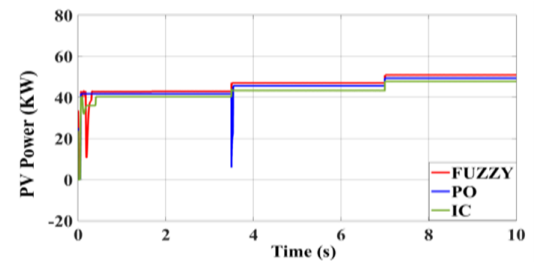

(c)

Fig. 15: The effect of changing the temperature on the output of the suggested model; (a) the PV's voltage, (b) the PV's current, and (c) the PV's power.

4.2. The influence of the gradual alteration in solar radiation on output.

1) The impact of solar radiation changes the PV's output.

In this instance, the solar radiation is variable while the temperature is constant (25oc). Where the solar radiation is gradually changed (700 W/m2, 1000 W/m2, and 400 W/m2) and the temperature is fixed at STC as shown in Fig. 17. As shown in Fig. 18, the output of a PV system using FLC is constant with a variety of solar radiation, and the energy is maximized without oscillation around MPP using FLC [21]. The power that comes out of PV can be illustrated by Table. 5.

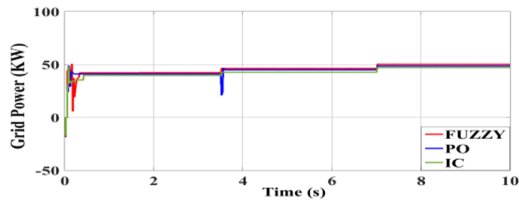

Fig. 16: The grid power is under the impact of three algorithms.

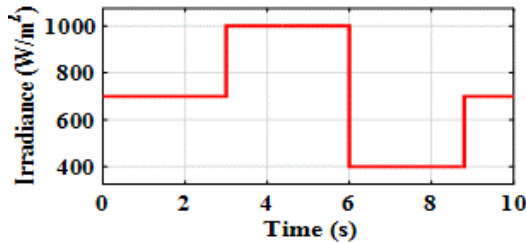

Fig. 17: Solar radiation.

2) The influence of solar radiation alteration on the grid's productivity.

The power out of the grid using the three methods is shown in Fig. 19, and Table 5 displays the results. From these figures, we conclude that FLC's method makes the voltage out of the PV system compatible with the voltage of the grid and that the current out of the matrix can be controlled.

5. Conclusion

This study introduces a full photovoltaic (PV) system, as well as its control systems, in the MATLAB/Simulink environment. The goal is to increase the system's maximum power point tracking (MPPT) efficiency by implementing a new control strategy based on the fuzzy logic controller (FLC) method. The suggested FLC approach improves system efficiency and responsiveness while decreasing oscillations in power, voltage, and current. In terms of the average rate of maximum electric energy created under varied weather circumstances, the FLC technique surpasses the perturb and observe (P&O) and incremental conductance (IC) approaches. The proposed system combines many methodologies and technologies to harvest the most power from the PV system and link it to the power grid.

Author Contributions

All authors contributed to the final version of the manuscript and all authors revised the manuscript.

Nabila Shehata, Ahmed Emad-Eldeen, and Walid S. Abdellatif supervised the project.

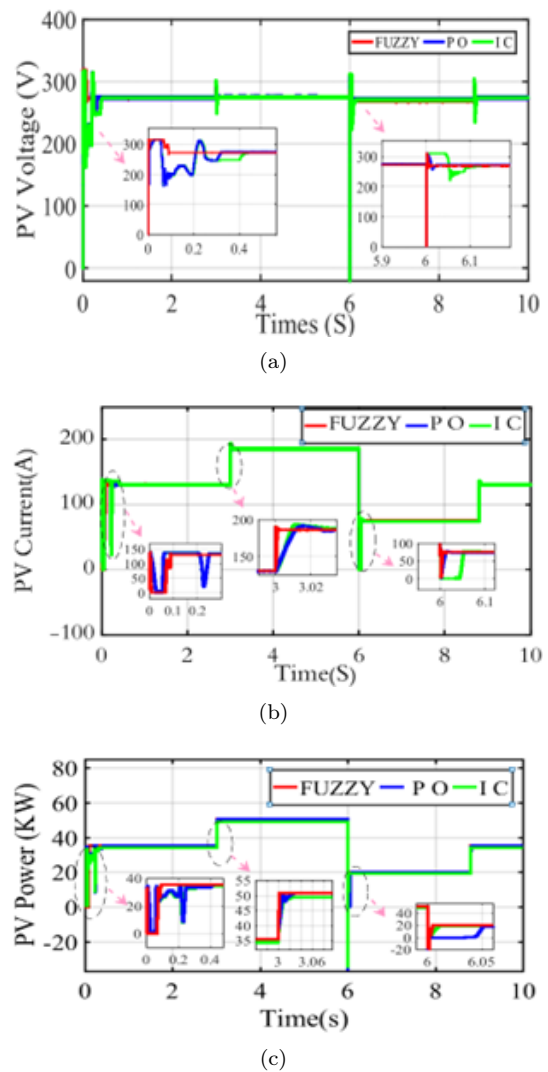

Fig. 18: The leverage of radiation on the functioning of the suggested system; (a) the module's voltage, (b) the module's current, and (c) the module's power.

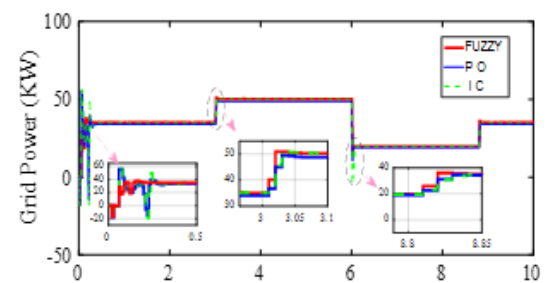

Fig. 19: Grid power using various techniques.

Tab. 5: PV power under different temperature.

Time (sec)	Solar Radiation (W/m ²)	(P kilowatt)		
		IC	P&O	FLC
0 : 3	700	33.37	34.45	35.53
3 : 6	1000	47.79	49.36	50.90
6 : 8.8	400	18.85	19.45	20.07
8.8 : 10	700	33.37	34.45	35.53

References

- [1] APURBA, M., DANIEL, P., MOHAMMAD, M. T., SUVERNA, T., PAWAN, K. AND PANKAJ, Y. A review of aspects of additive engineering in perovskite solar cells. *J. Mater. Chem.* 2020, vol. 8, 27–54, no. 1, pp. 27–54. DOI: 10.1039/C9TA07657C.
- [2] SAAD A. MOHAMED ABDELWAHAB, ADEL A. ELBASET, FAHD YOUSEF, WALID S.E. ABDELLATIF. Performance Enhancement of PV Grid Connected Systems with Different Fault Conditions. *International Journal on Electrical Engineering & Informatics*, Vol. 13 No. 4, December 2021. DOI: 10.15676/ijeei.2021.13.4.8.
- [3] S. S. DESSOUKY, S. A. M. ABDELWAHAB, W. S. E. ABDELLATIF, AND M. A. ALI. Performance enhancement of grid connected PV system by using ICMPTT technique. *Journal of Scientific and Engineering Research*, vol. 5, no. 3, pp. 271–279, 2018.
- [4] S. A. M. ABDELWAHAB, A. M. HAMADA, AND W. S. E. ABDELLATIF. Comparative Analysis of the Modified Perturb & Observe with Different MPPT Techniques for PV Grid Connected Systems. *International Journal of Renewable Energy Research*, vol.10, no.1, March, 2020. DOI: 10.12720/sgece.10.4.253-269.
- [5] A. RAJAVEL AND N. RATHINA PRABHA. Fuzzy logic controller-based boost and buck-boost converter for maximum power point tracking in solar system. *Trans. Inst. Meas. Control.* 2021, vol. 43, no. 4, pp. 945–957, DOI: 10.1177/0142331220938211.
- [6] D. VERMA, S. NEMA, A. M. SHANDILYA AND S. K. DASH. Maximum power point tracking (MPPT) techniques: Recapitulation in solar photovoltaic systems. *Renew. Sustain. Energy Rev.* 2016, vol. 54, pp. 1018–1034, DOI: 10.1016/j.rser.2015.10.068
- [7] H. SHAHID, M. KAMRAN, Z. MEHMOOD, M. Y. SALEEM, M. MUDASSAR AND K. HAIDER. Implementation of the novel temperature controller and incremental conductance MPPT algorithm for indoor photovoltaic system. *Sol. Energy.* 2018, vol. 163, pp. 235–242. DOI: 10.1016/j.solener.2018.02.018.
- [8] M. AL-DHAIFALLAH, A. M. NASSEF, H. REZK AND K. S. NISA. Optimal parameter design of fractional order control based INC-MPPT for PV system. *Sol. Energy.* 2018, vol. 159, pp. 650–664, DOI: 10.1016/j.solener.2017.11.040.
- [9] R. I. PUTRI, S. WIBOWO AND M. RIFA'I. Maximum power point tracking for photovoltaic using incremental conductance method. *Energy Procedia.* 2015, vol. 68, pp. 22–30. DOI: 10.1016/j.egypro.2015.03.228
- [10] W. S.E. ABDELLATIF, M. S. MOHAMED, S. BARAKAT, AND A. BRISHA. A Fuzzy Logic controller based MPPT technique for photovoltaic generation system. *J International Journal on Electrical Engineering & Informatics*, vol. 10 ,no. 2, June 2021. DOI: 10.15676/ijeei.2021.13.2.9.
- [11] K. JAIN, M. GUPTA AND A. KUMAR BOHRE. Implementation and Comparative Analysis of PO and INC MPPT Method for PV System. In: India Int. Conf. Power Electron. IICPE. 2018, pp. 1–6. DOI: 10.1109/IICPE.2018.8709519.
- [12] E. A. GOUDA, M. F. KOTB AND D. A. ELALFY. Modelling and Performance Analysis for a PV System Based MPPT Using Advanced Techniques. *Eur. J. Electr. Eng. Comput. Sci.* 2019, vol. 3, pp. 1–7. DOI: 10.24018/ejece.2019.3.1.47.
- [13] A. GHAMRAWI, J. P. GAUBERT AND D. MEHDI. A new dual-mode maximum power point tracking algorithm based on the Perturb and Observe algorithm used on solar energy system. *Sol. Energy.* 2018, vol. 174, pp. 508–514. DOI: 10.1016/j.solener.2018.09.013.
- [14] S. SINGH, S. MANNA, M. I. H. MAN-SOORI AND A. K. AKELLA. Implementation of Perturb Observe MPPT Technique using Boost converter in PV System. In: Int. Conf. Comput. Intell. *Smart Power Syst. Sustain. Energy*, CISPSSE. 2020, pp. 29–32. DOI: 10.1109/CISPSSE49931.2020.9212203.
- [15] R. ARULMURUGAN. Optimization of Perturb and Observe Based Fuzzy Logic MPPT Controller for Independent PV Solar System. *Wseas Trans. Syst.* 2020, vol. 19, pp. 159–167. DOI: 10.37394/23202.2020.19.21.
- [16] SAAD A. MOHAMED ABDELWAHAB, MOAYED MOHAMED, MOHAMED EBEED, W. S. E ABDELLATIF. Equilibrium Optimizer and FLC of Two Area Load Frequency

- control with Multi-Source Generators System. *International Journal of Renewable Energy Research (IJRER)*, Volume 12, No 4,2022. DOI: 10.20508/ijrer.v12i4.13440.g8588.
- [17] NAHAK AND Y. PAL. Comparison between conventional, and advance maximum power point tracking techniques for photovoltaic power system. In: *IEEE 7th Power India Int. Conf, PIICON* .2016. DOI: 10.1109/POWERI.2016.8077200.
- [18] T. H. KWAN AND X. WU. Maximum power point tracking using a variable antecedent fuzzy logic controller. *Sol. Energy*. 2016, vol. 137, pp. 189-200. DOI: 10.1016/j.solener.2016.08.008.
- [19] M. A. DANANDEH AND S. M. MOUSAVI G. A new architecture of INC-fuzzy hybrid method for tracking maximum power point in PV cells. *Sol. Energy*. 2018, vol. 171, pp. 692–703. DOI: 10.1016/j.solener.2018.06.098.
- [20] S. A. M. ABDELWAHAB, H. Y. HEGAZY, W. I MOHAMED. Experimental investigation and theoretical for the performance improvement of MPPT technique with PV systems connected to the grid. *International Journal of Smart Grid and Clean Energy*, vol. 10, no. 4, October 2021. DOI: 10.12720/sgce.10.4.253-269.
- [21] A. M. ELTAMALY, M. S. AL-SAUD AND A. G. ABOKHALIL. A novel scanning bat algorithm strategy for maximum power point tracker of partially shaded photovoltaic energy systems. *Ain Shams Eng. J.* 2020, vol. 11, no. 4, pp. 1093–1103. DOI: 10.1016/j.asej.2020.02.015.
- [22] P. K. PATHAK AND A. K. YADAV. Design of battery charging circuit through intelligent MPPT using SPV system. *Sol. Energy*. 2019, vol. 178, pp. 7-89. DOI: 10.1016/j.solener.2018.12.018.
- [23] J. A. RAMOS HERNANZ, J. J. CAMPAYO MARTÍN, I. ZAMORA BELVER, J. LARRAÑAGA LESAKA, E. ZULUETA GUERRERO AND E. PUELLES PÉREZ. Modelling of photovoltaic module. *Renew. Energy Power Qual. J.* 2010, vol. 1, no. 8, pp. 1186-1190.
- [24] A. E. A. HUSSIEN, N. SHEHATA, A. EMAD-ELDEEN, S. A. M. ABDELWAHAB, W.S. E. ABDELLATIF. Investigation of Perturb and Observe MPPT Technique for Photovoltaic Systems: Theoretical and Experimental Study. *International Middle East Power Systems Conference (MEPCON)*, Mansoura, Egypt, 2023.